

Sun 2000 Solar Simulators

Cost effective and versatile UV to IR sources



Abet Technologies Model 11048-1 3 kW multi-sun UV solar simulator, customer reconfigurable to a full spectrum 2 suns 300x300 mm field simulator.

Abet Technologies' Sun 2000 family of solar simulators, characterized by Class B irradiance uniformity performance, covers wide range of illuminated field sizes, 55x55 mm through 400x400 mm, square or rectangular. One sun and High Output models are offered. AM 1.5G spectrum models are complemented by a variety of other spectral offerings: AM 0, AM 1D, AM 1.5 D, AM 2D, Atmospheric UV Edge, and UV C, UV B/C, and UV A/B/C blocked, full spectrum, UV only and spectrum switchable models.



Abet Technologies Model 11044 Sun 2000 203 x 203 mm Solar Simulator.

Innovative and complete

The Abet Gen II optical design dramatically increases the percentage of photons reaching the work plane. This higher optical efficiency allows the use of lower power lamps to illuminate a given size field, e.g. more than one AM 1.5G sun is achieved with a 550 W lamp over a 160x160 mm field.

All electronics are packaged in the lamp house – no clutter of high power cables to deal with. A digital shutter timer allowing both manual and external control is included with every unit.

Standard maintenance, lamp or filter replacement, does not require any tools.

Locking indicator dials on all the system controls provide for a reproducible and stable setup.

Most units come with a built-in beam imaging accessory to assist in system alignment.

Clean Cooling

Any dust or dirt particles introduced into an optical system can degrade system performance and shorten the life of critical optical components. Sun 2000 sources utilize a HEPA filtered cooling air to extend the life of the delicate optical components.

- Gen II Optics for High Efficiency Illumination
- Class A Spectral Match to the applicable standard
- **Class A stability**
- Class B Uniformity
- DC Xe Arc Lamp, 150W to 3 kW
- Wide range of Working Distances
- Full Spectrum/UV Switchable models
- Long Life Shutter Included
- Digital Shutter Timer Included
- Long Life Lamps
- HEPA Filtered Cooling

Adaptable

Abet Technologies offers a number of spectral and field size options to match your application. The Sun 2000 family standard offerings range from 55x55 mm to 400x400 mm one sun or more uniformly illuminated field versions for Photovoltaic and UV applications.

Standard High Output models offer over 20 AM 1.5G Suns. Higher irradiances are available from concentrated models.

Square and rectangular illuminated field models to match device shapes and sizes.

Up-pointing and horizontal output direction models complement the standard down pointing ones.

Long working distances allow easy interface to glove boxes.

The compact design of the systems, combined with the long working distance optics, leaves the space below these instruments wide open for any sample positioning or testing equipment.

Beyond the standard AM 1.5 and AM 0 filters many other filters are offered to fine tune the spectral characteristics of the source for your particular application.

Sun 2000 Solar Simulator Specifications, 1 sun models

Model #	Field size (mm)	Stability (%)	Uniformity (%)	Lamp (W)	Ozone free	Lamp life (hours)	Working distance (mm typ.)	Irradiance AM 1.5G suns (max. typ.)	AM 1.5G spectral match
11000	55x55	1	5	150	☑	1500	125±25	1.3	A
11016	100x100	1	5	550	☑	1500	100±50	2.1	A
11018	160x160	1	5	550	☑	1500	200±50	1.3	A
11044	203x203	1	5	1000	☑	1500	200±50	1.3	A
11046	254x254	1	5	1400	☑	1500	200±50	1.3	A
11047	100x250	1	5	1000	☑	1500	200±50	1.3	A
11048	300x300	1	5	2000	☑	2000	400±75	1.3	A

The Sun 2000 models listed above are most popular with our customers. They deliver around one sun irradiances and limit UV exposure by utilizing an N-BK7 condenser lens. However, if your test needs require a multi-sun level of irradiance see page 11 in this brochure. For systems with UV content matching AM0 or terrestrial atmospheric UV edge see page 12. Pages 14-17 offer similar systems in the Abet Technologies Sun 3000 Class AAA family of Solar Simulators. The above are the most popular field size models. Please let us know if your needs require a different one – many additional square and rectangular shaped field size systems can easily be manufactured.

Certified

Each Sun 2000 Solar Simulator for which standards exist ships with a performance certificate according to the customer selected standard: ASTM, IEC or JIS.

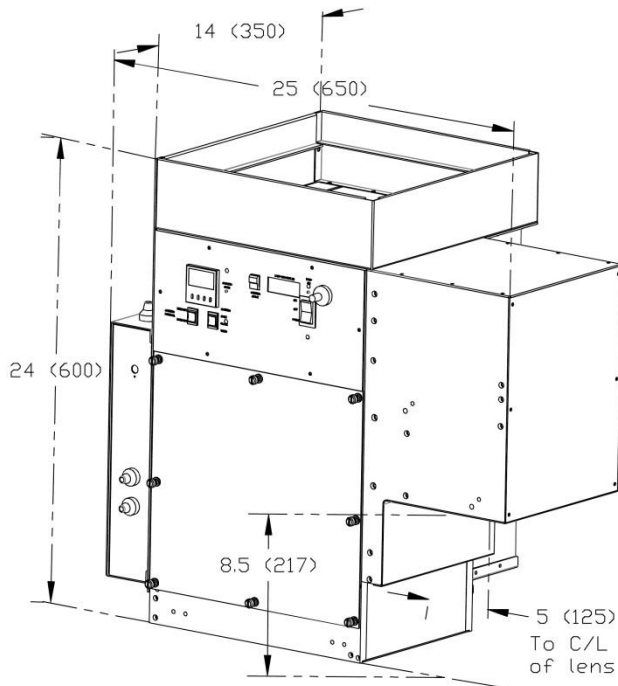

Dimensional diagram of the Abet Technologies model 11000 Sun 2000 Solar Simulator

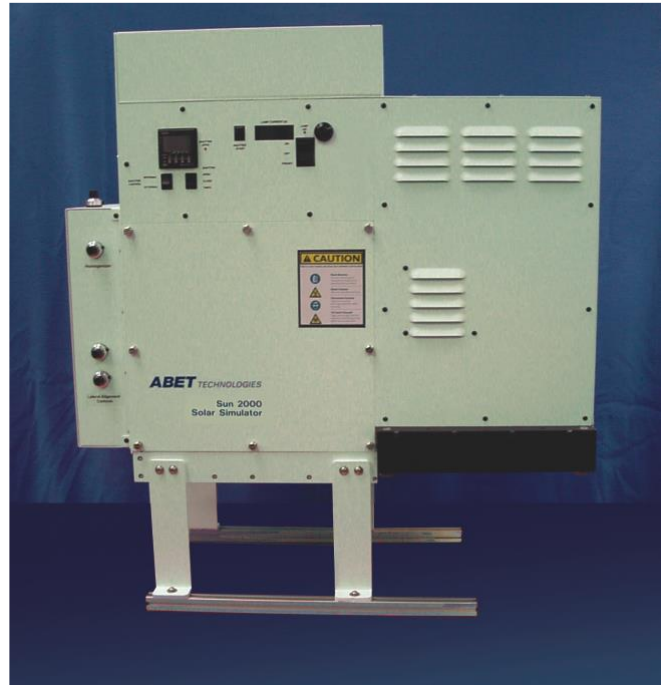

Abet Technologies Model 11018 Sun 2000 160x160 mm Solar Simulator

Available Options

All models listed above include an AM 1.5G filter for ordering convenience. Other filter options can be substituted or added at the time of ordering.

Working distances listed above are typical – many additional solutions are available. In particular, the up-pointing and horizontal output models are often shipped with longer working distances to accommodate a glove box or more complex test bench requirements.

The 11088 Photofeedback option is no longer necessary to achieve Class A stability performance.

The 11075 Attenuator Set allows great flexibility in irradiance control for 150-550 W systems.

See the ordering information on page 13 for a list of standard options. Please contact Abet if you need something different.

Sun 2000 Solar Simulators, High Output models

Model #	Field size (mm)	Stability (%)	Uniformity (%)	Lamp (W)	Ozone free	Lamp life (hours)	Working distance (mm typ.)	Irradiance AM 1.5G suns (max. typ.)	AM 1.5G spectral match
11014	55x55	1	5	550	☑	1500	125±25	7	A
11038	55x55	1	5	1000	☑	1500	125±25	12	A
11040	100x100	1	5	1000	☑	1500	100±50	4	A
11042	160x160	1	5	1000	☑	1500	200±50	2	A
11048	300x300	1	5	3000	☑	1500	400±75	2.1 (3.2) ¹	A

¹ With the 14205 field reducer option

The Sun 2000 models listed above are most popular with our customers. They deliver multi-sun irradiances and limit UV exposure by utilizing an N-BK7 condenser lens. For systems with UV content matching AM0 or terrestrial atmospheric UV edge see page 12. Pages 13-16 offer similar systems in the Abet Technologies Sun 3000 Class AAA family of Solar Simulators.

Many other combinations of lamp power levels and field sizes can be easily assembled without any additional engineering charges. For field sizes up to 254x254 mm any of the standard lamps, 150W, 300W, 550W, 1000W, or 1400W can be used, when matched to the appropriate power supply selection, to obtain a wide variety of irradiance levels.

Certified

Each Sun 2000 Solar Simulator for which standards exist ships with a performance certificate according to the customer selected standard: ASTM, IEC or JIS.



Abet Technologies Model 11014 Sun 2000 High Output 55x55 mm Solar Simulator

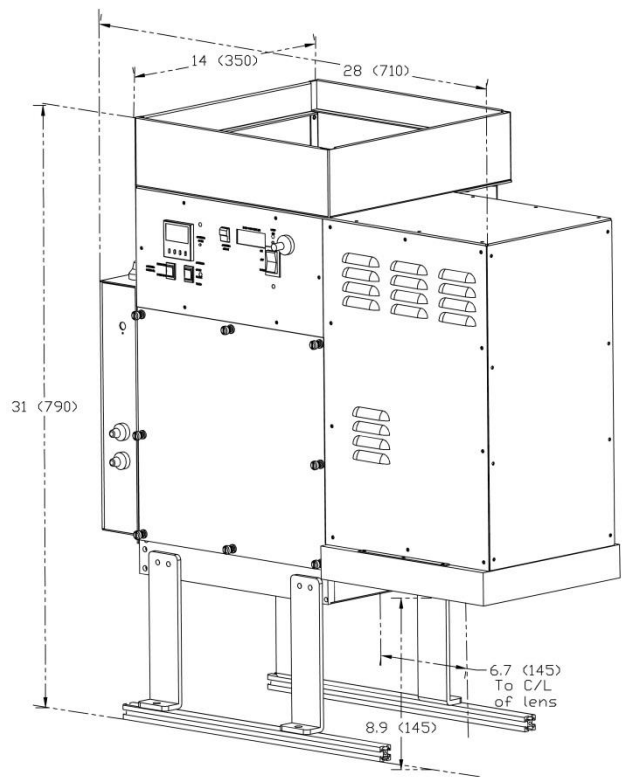

Dimensional diagram of the Abet Technologies model 11018 and 11042 Sun 2000 Solar Simulators

Available Options

All models listed above include an AM 1.5G filter for ordering convenience. Other filter options can be substituted or added at the time of ordering.

Working distances listed above are typical – many additional solutions are available. In particular, the up-pointing and horizontal output models are often shipped with longer working distances to accommodate a glove box or more complex test bench requirements.

The 11088 Photofeedback option is no longer necessary to achieve Class A stability performance.

See the ordering information on page 13 for a list of standard options. Please contact Abet if you need something different.

Sun 2000 Solar Simulators, Full Spectrum and UV models

Model #	Spectrum (nm)	Field size (mm)	Stability (%)	Uniformity (%)	Lamp (W)	Ozone free	Lamp life (hours)	Working distance (mm typ.)	Irradiance UV suns (max. typ.)
12060-1	280-400	160x160	1	5	1400	<input checked="" type="checkbox"/>	1500	200±50	6
12060-2	280-2500	160x160	1	5	1400	<input checked="" type="checkbox"/>	1500	200±50	6
12060-3	Switchable	160x160	1	5	1400	<input checked="" type="checkbox"/>	1500	200±50	6

Any of the SUN 2000 models on the previous and following pages can be ordered as Full Spectrum, UV, or Switchable by adding a -1, -2, or -3 suffix to its model number as shown in the example above. All of these systems are equipped with a Fused Silica condenser lens. The “-1” units replace one of the mirrors with a 280-400 nm Dichroic Reflector to allow accelerated UV aging tests without excessive heating of the test devices. The “-2” Full Spectrum (280-2500 nm) units are often used with an AM 1.5G or AM 0 filter. The “-3” systems allow operation in either mode – full spectrum or 280-400 nm by a simple swap of frame mounted reflectors. This option can be customer added to either “-1” or “-2” models when the need arises.

Certified

Each Sun 2000 Solar Simulator for which standards exist ships with a performance certificate according to the customer selected standard: ASTM, IEC or JIS.

Spectrally corrected

A number of filter options are available for these systems to match their performance to the test requirements: AM 0 filter for extraterrestrial cells, Atmospheric Edge (AE) filter for terrestrial cells with response below 360 nm and for life sciences, UVC, UVB/C, and UVA/B/C blocking filters for material and life sciences.

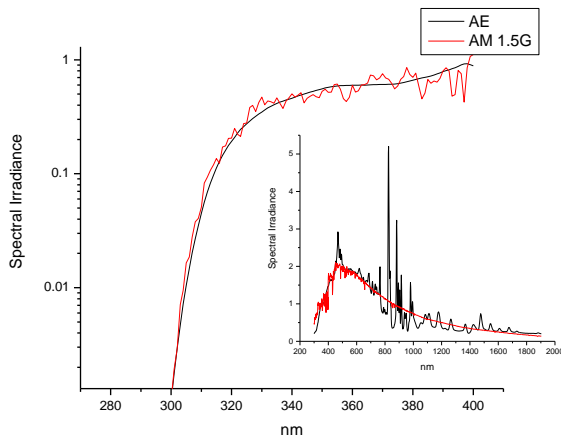

Atmospheric Edge (AE) filtered output of 11042-1 system (black), scaled down, overlaid with the AM 1.5G UV spectrum (red).
 Insert: AMO filtered output of model 11016-2 system (black) overlaid with the AM0 spectrum (red).

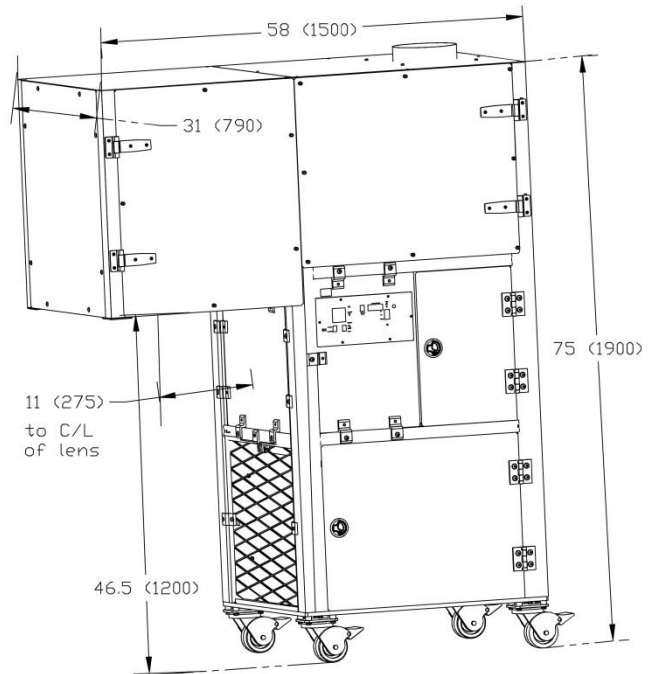

Dimensional diagram of the Abet Technologies model 11048 Sun 2000 Solar Simulator

Available Options

Many combinations of lamp power levels and field sizes can be easily assembled without any additional engineering charges. For field sizes up to 254x254 mm any of the standard lamps, 150W, 300W, 550W, 1000W, or 1400W can be used, when matched to the appropriate power supply selection, to obtain a wide variety of irradiance levels. High UV output “-1” 280-400 nm models are often used for accelerated UV damage testing.

See the ordering information on page 13 for a list of standard options. Please contact Abet if you need something different.

Sun 2000 Specifications

Illumination field.....55x55 to 400x400 mm
 Irradiance.....1 to 20 suns
 Spectral Match with AM 1.5G, AM 0, AM 1.5D Filters
 ASTM.....Class A
 IEC.....Class A
 JIS.....Class A
 Temporal Stability
 ASTM.....Class A
 IEC.....**Class A**
 JIS.....Class A
 Irradiance uniformity
 ASTM.....Class B
 IEC.....Class B
 JIS.....Class B
 Ozone-free Xe Arc Lamp (included)150 to 3000 W
 Typical life1500 hours
 HEPA filtered cooling fan included
 Elapsed Time Meter (included)
 Universal Input 90-250V, 50-60Hz, power supply included
 Standard Output Direction.....Down pointing

Abet Technologies regularly continues to upgrade our products, therefore all specifications are subject to change without notice.

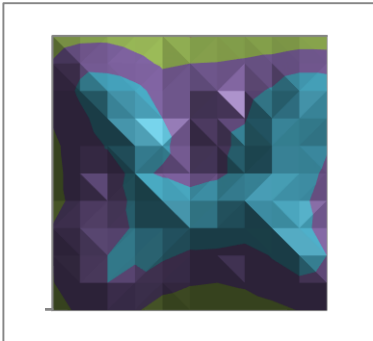

Non-uniformity map of an Abet Technologies model 11016 Solar Simulator, 110x110 mm, 3%.

Ordering Information

All standard Sun 2000 Solar Simulators include a Lamp, a Universal Input 90-250V Power Supply, an AM 1.5G Filter and a N-BK7 condenser lens. Add "-2" for a Fused Silica condenser lens, "-1" for a 280-400 nm dichroic option, "-3" for a Full Spectrum/280-400 nm convertible unit; add "U" for up-pointing option, "H" for horizontal output.

- 11000** 55x55 mm, 150 W
- 11014** 55x55 mm, 550 W
- 11038** 55x55 mm, 1000 W
- 11016** 110x110 mm, 550 W
- 11040** 110x110 mm, 1000 W
- 11018** 160x160 mm, 550 W
- 11042** 160x160 mm, 1000 W
- 12060** 160x160 mm, 1400 W
- 11044** 203x203 mm, 1000 W

- 11045** 100x250 mm, 1000 W
- 11046** 254x254 mm, 1400 W
- 11048** 300x300 mm, 2000 W

Accessories and options

- 11054** AM 0 filter, 2x2 in.
- 11056** AM 1.5G filter, 2x2 in.
- 11058** AM 1.5D filter, 2x2 in.
- 11057** AM 1D filter, Ø 3 in.
- 11059** AM 2D filter, Ø 3 in.
- 11060** UVA/B/C Blocking Filter, Ø 3 in.
- 11063** AE filter (Atmospheric Edge), Ø 3 in.
- 12163** AE filter for 300x300 mm systems
- 11064** UVC Blocking Filter, Ø 3 in.
- 11065** UVB/C Blocking Filter, Ø 3 in.
- 11051** Replacement HEPA filter
- 11068** Beam Attenuator - 21%
- 11069** Beam Attenuator - 33%
- 11070** Beam Attenuator - 50%
- 11071** Beam Attenuator - 60%
- 11072** Beam Attenuator - 67%
- 11073** Beam Attenuator - 77%
- 11075** Attenuator Set - All Six Attenuators
- 11088** Photofeedback option, 0.5% stability
- 14205** Field reducer assembly, 300x300 to 200x200 mm
- 11051** HEPA Filter
- 12185** System Elevator, Adjustable Height Mount
- 13014** 150 W Xenon Arc Lamp
- 13020** 300 Watt Xenon Arc Lamp, OF
- 13021** 550 Watt Xenon Arc Lamp, OF
- 13024** 1kW Xenon Arc Lamp, OF
- 13025** 1.4kW Xenon Arc Lamp, OF
- 13026** 2.0kW Xenon Arc Lamp, OF
- 13027** 3.0kW Xenon Arc Lamp, OF

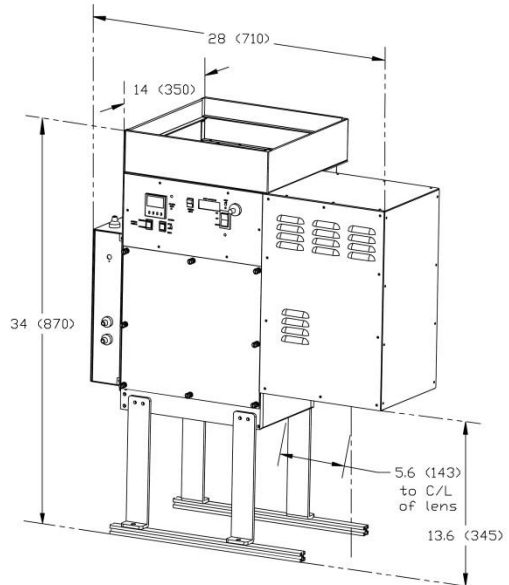

Dimensional diagram of the Abet Technologies model 11016 and 11040 Sun 2000 Solar Simulators