

H101A

114 x 75 mm motorised scanning stage for upright microscopes



The H101A has an adaptation system to allow one universal stage to fit many microscopes. The stage is compatible with sample holders for up to four standard slides, semiconductor wafers, metallurgical specimens, Microtitre plates or Petri dishes. Incorporating the Prior IST system, this stage is reliable, versatile and precise and is controlled via Prior's versatile ProScan® system.

- < 1µm resolution
- Interchangeable and low profile sample holders
- At least ±0.7 µm repeatability
- RS232 and USB controlled, and compatible with most 3rd party software.
- Accepts linear encoders
- Choice of motor type and high precision ball screw
- Travel range of 114 x 75 mm
- Anti-backlash mechanism and adjustable limit switches

Dimensions

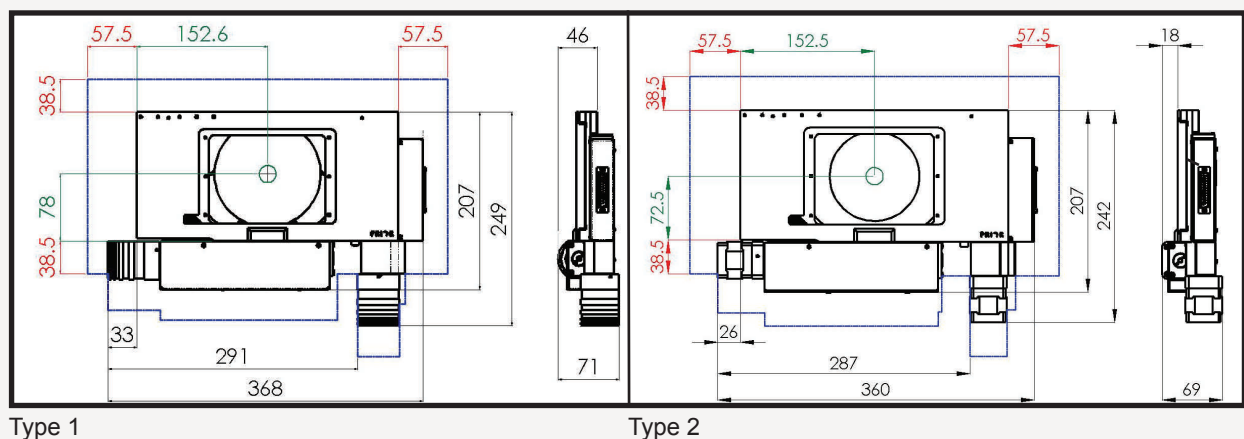

H101A

114 X 75 mm motorised scanning stage for upright microscopes

Specification

Performance*	H101A	HIPIA	HIP4A	HEO1A	HEPIA	HEP4A
Bi Directional Repeatability (Mean) in μm	± 2.2 (1.3)	± 2 (1)	± 2 (0.9)	± 1.5 (0.8)	± 1.5 (0.8)	± 1.5 (0.6)
Uni Directional Repeatability (Mean) in μm	± 0.7 (0.2)	± 0.7 (0.2)	± 0.7 (0.2)	± 0.7 (0.2)	± 0.7 (0.2)	± 0.7 (0.2)
Minimum Step Size in μm	0.04	0.02	0.01	0.04	0.02	0.01
Recommended Speed (Maximum speed) in mm per seconds	40 (100)	20 (50)	15 (25)	40 (100)	20 (50)	15 (25)
Metric accuracy per mm of travel (Average performance)	0.2 (0.06)	0.2 (0.059)	0.2 (0.059)	0.2 (0.057)	0.2 (0.046)	0.2 (0.046)
Maximum travel range in mm	114 x 75	114 x 75	114 x 75	114 x 75	114 x 75	114 x 75
Maximum load in kg	10	10	10	10	10	10
Squareness in arc sec	30	30	30	30	30	30
Weight in kg	5	5	5	5	5	5
Type	1	1	2	1	1	2
Ball Screw Pitch	2	1	1	2	1	1
Motor Type SPR**	200	200	400	200	200	400
Encoder***	NO	NO	NO	YES	YES	YES

* To obtain these values requires the use of a Prior ProScan II or above controller. These values were obtained using a Prior ProScan Controller, with backlash correction and IST enabled, over the full travel range of the scan using the Prior method of testing. All repeatability is uni-directional.

** SPR = full Steps per Revolution of Motor

*** 0.1 μm res encoding provided.



Prior Scientific Ltd

3-4 Fielding Industrial Estate • Wilbraham Road • Fulbourn • Cambridge • CB21 5ET • UK

t: +44 (0)1223 881711 • e: uksales@prior.com • www.prior-scientific.co.uk



FM 61600



Prior Scientific Inc

80 Reservoir Park Drive • Rockland • MA. 02370 • U.S.A.

t: +1 781-878-8442 • e: info@prior.com • www.prior-us.com

Registered Address: Units 3/4 Fielding Industrial Estate • Wilbraham Road • Fulbourn • Cambridge • CB21 5ET • United Kingdom Registered in England 404087